



# Welcome to our Annual report 2018

## Contents

- 01 Highlights
- 02 Report of the directors
- 05 Independent auditor's report
- 11 Profit or loss account
- 13 Statement of changes in equity
- 14 Balance sheet
- 16 Notes to the financial statements
- 38 Directors and advisors

Beazley Insurance dac reinsures and provides capital to support the underwriting activities of Beazley Underwriting Limited in the Lloyd's market. The company also writes non-life insurance through its European branch network.



# Highlights

Gross premiums written

**\$104.6<sup>1</sup>m**

(2017: \$1,411.6m)

Net investment income

**\$29.7<sup>1</sup>m**

(2017: \$126.8m)

Earned premiums, net of reinsurance

**\$99.0<sup>1</sup>m**

(2017: \$1,334.0m)

Cash and investments

**\$1,420.5m**

(2017: \$1,257.4m)

Profit after tax for the financial year

**\$43.8m**

(2017: \$85.4m)

<sup>1</sup> During the year, the reinsurance contracts already in place with Beazley Underwriting Limited were endorsed, with amended terms in relation to profit retention and excess of loss ('the new contracts'). Under the new contracts, a single premium or claim balance is recognised under each contract if at the reporting date the underlying result of the syndicates is a profit or a loss (subject to excesses). In this regard, this balance is not directly comparable to prior year balances.

Further information on the accounting treatment of the new contracts is presented in the notes on pages 16 to 37 which form part of these financial statements.

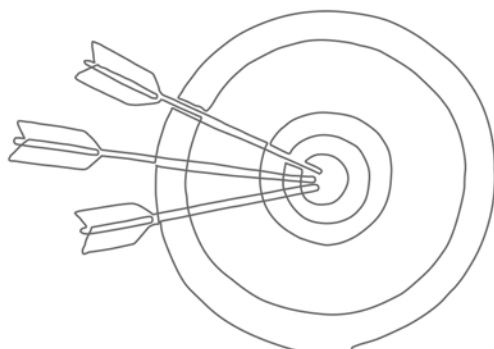

# Report of the directors

The directors submit their report, together with the financial statements of the company for the year ended 31 December 2018.

## Principal activities and business review

In July 2017 the company received authorisation from the Central Bank of Ireland to convert from a reinsurance company into a non-life insurance company permitted to transact business throughout the European Union. To that end the company was renamed Beazley Insurance dac. The company operates a branch network in the United Kingdom, France, Germany and Spain and operates across Europe on a freedom of services basis. The initial focus of the business is on specialty lines business. The company underwrote its first policies for European banks in the fourth quarter of 2017. 2018 was the first full year of operations of the non-life insurance business. The company continues to invest in and develop its business across Europe.

The company also continues to act as an intra-group reinsurer and provides capital to support the underwriting activities of its sister company, Beazley Underwriting Limited. Beazley Underwriting Limited is a Lloyd's of London corporate member. It participates in the Lloyd's insurance market on a limited liability basis through syndicates 2623, 3622 and 3623. During 2018, the terms of this aggregate excess of loss reinsurance agreement with Beazley Underwriting Limited changed following negotiation between both companies. As part of the negotiation of the contract covering the 2019 underwriting year, a profit retention of \$4m was added to the contract and the excess of loss was increased from £2m to \$4m. Over these amounts, Beazley Underwriting Limited cedes 75% of the final declared result of its participation in syndicates 2623 and 3623. In the event that the declared result is a loss, the extent of the reinsurance is limited to the loss in excess of \$4m not exceeding 75% of the Funds at Lloyd's. As part of the negotiation of the 2019 contract, the open contracts in respect of the 2016, 2017 and 2018 underwriting years were endorsed so as to also include the same terms.

The accounting treatment of these new reinsurance contracts is different to the accounting treatment of the previous reinsurance contracts. These new reinsurance contracts result in a single premium or claim balance being recognised under each contract if at the reporting date the underlying result of the syndicates is a profit or a loss (subject to excesses). These changes were enacted from 1 January 2018 and therefore have been applied prospectively; meaning the prior year profit or loss account, balance sheet and notes to the financial statements are not directly comparable to current year balances on a line by line basis.

The directors are satisfied that the accounting treatment of the new reinsurance contracts is the most appropriate to reflect the reinsurance activities of the company.

The company also has a credit facility agreement with Beazley Underwriting Limited. Under this agreement, the company provides 25% of Beazley Underwriting Limited's total required Funds at Lloyd's, subject to a minimum amount as defined by the agreement on an annual basis.

## Future developments in the business

The reinsurance contract for 2019 was signed by the company and Beazley Underwriting Limited on 10 December 2018. The company will seek to grow and expand its new non-life insurance business across Europe through the launch of new products and additional underwriting capability. In 2019, the company has begun writing property treaty business and has obtained authorisation to write other non-specialty lines business. The company is in the process of opening a Swiss branch and has submitted an application to the PRA for authorisation of its UK branch as a third country branch, due to Brexit.

## Principal risks and uncertainties

Due to the nature of its activities, the principal risks and uncertainties of the company are aligned with those of 'Beazley plc' (the group) and include:

- Insurance risk
- Asset risk
- Operational risk
- Liquidity risk
- Credit risk
- Group risk
- Regulatory and legal risk
- Strategic risk

Brexit has been considered as part of the above risks.

The group operates a risk management framework, within which risk appetite is defined, risks assumed are identified and managed and key controls are implemented and monitored.

## Key performance indicators ('KPIs')

Profit before tax was \$49.0m (2017: \$95.8m). Return on equity for the year was 4% (2017: 8%).

## Results and dividends

The result for the year is shown on the profit or loss account on pages 11 and 12. The company paid £56.7m, being £56.7m per share, dividends in 2018 (2017: £66m) to its sole shareholder Beazley Ireland Holdings plc.

## Directors

The names of the persons who were directors at any time during the year ended 31 December 2018 are set out below:

### Director

M L Bride (French)	
P O DeSaulle (French)	(Independent non-executive)
D A Horton (British)	
E J McGivney	
K P Murphy	(Independent non-executive - appointed 27 July 2018)
I C Stuart	(Independent non-executive)
C M Woods	(Independent non-executive chairperson)

## Directors and secretary and their interests

The directors and secretary who held office at 31 December 2018 had no interests greater than 1% in the shares of, or debentures or loan stock of, the company or group companies at the beginning (or date of appointment, if later) or end of the year.

## Statement of directors' responsibilities

The directors are responsible for preparing the report of the directors' and the financial statements in accordance with applicable law and regulations.

Company law requires the directors to prepare financial statements for each financial year. Under that law they have elected to prepare the financial statements in accordance with FRS 102 The Financial Reporting Standard applicable in the UK and Republic of Ireland and FRS 103 Insurance contracts.

Under company law the directors must not approve the financial statements unless they are satisfied that they give a true and fair view of the assets, liabilities and financial position of the company and of its profit or loss for that year.

In preparing these financial statements, the directors are required to:

- select suitable accounting policies and then apply them consistently;
- make judgments and estimates that are reasonable and prudent;
- state whether applicable Accounting Standards have been followed, subject to any material departures disclosed and explained in the financial statements;
- assess the company's ability to continue as a going concern, disclosing, as applicable, matters related to going concern; and
- use the going concern basis of accounting unless they either intend to liquidate the company or to cease operations, or have no realistic alternative but to do so.

The directors are responsible for keeping adequate accounting records which disclose with reasonable accuracy at any time the assets, liabilities, financial position and profit or loss of the company and enable them to ensure that the financial statements comply with the Companies Act 2014 and the European Union (Insurance Undertakings: Financial Statements) Regulations 2015. They are responsible for such internal controls as they determine is necessary to enable the preparation of financial statements that are free from material misstatement, whether due to fraud or error, and have general responsibility for taking such steps as are reasonably open to them to safeguard the assets of the company and to prevent and detect fraud and other irregularities. The directors are also responsible for preparing a directors' report that complies with the requirements of the Companies Act 2014.

As required by Section 325 of the Companies Act 2014 (the '2014 Act'), the company confirms that it has established an audit committee, which assists the board in carrying out its oversight and control obligations.

## Report of the directors *continued*

### Relevant audit information

We confirm that to the best of our knowledge:

- so far as the directors are aware, there is no relevant audit information of which the company's statutory auditors are unaware; and
- the directors have taken all the steps that he or she ought to have taken as a director in order to make himself/herself aware of any relevant audit information and to establish that the company's statutory auditors are aware of that information.

### Statement of directors' compliance

The directors of the company acknowledge that they are responsible for securing the company's compliance with its relevant obligations (as defined in the 2014 Act) and, as required by Section 225 of the 2014 Act.

The directors confirm that:

- a compliance policy statement setting out the company's policies with regard to complying with the relevant obligations under the 2014 Act has been prepared;
- arrangements and structures have been put in place that they consider sufficient to secure material compliance with the company's relevant obligations; and
- a review of the arrangements and structures has been conducted during the financial year to which this directors' report relates.

### Accounting records

The directors believe that they have complied with the requirements of sections 281 to 285 of the Companies Act, 2014 with regard to books of account by employing accounting personnel with appropriate expertise and by providing adequate resources to the financial function. The books of account of the company are maintained at 2 Northwood Avenue, Santry, Dublin 9 (D09 X5N9).

### Political donations

The company made no political donations during the financial year ending 31 December 2018 or 31 December 2017; neither above or below €200.

### Central Bank of Ireland Corporate Governance Code

The company is subject to the Corporate Governance Requirements for Insurance Undertakings issued by the Central Bank of Ireland. The company is not required to comply with the additional requirements for major institutions.

### Post balance sheet events

No events occurred in the period post year end to the date of signing the financial statements that would impact the results, operations or note disclosures of the financial statements of the company.

### Auditor

KPMG, Chartered Accountants acted as auditor for the year ended 31 December 2018. KPMG are required to resign as auditor under the mandatory firm rotation rules of Regulation (EU) No 537/2014 following this year's audit.

At a general meeting of the company, it was resolved that Ernst and Young be appointed as auditor as of the financial year 2019. This followed a selection procedure in accordance with Article 16(3) of Regulation (EU) No 537/2014 in respect of the appointment of the audit firm.

On behalf of the Board

Catherine Woods  
*Director*

Ed McGivney  
*Director*

15 April 2019



**KPMG**  
**Audit**  
1 Harbourmaster Place  
IFSC  
Dublin 1  
D01 F6F5  
Ireland

## **INDEPENDENT AUDITOR'S REPORT TO THE MEMBERS OF BEAZLEY INSURANCE DAC**

### **Report on the audit of the financial statements**

#### ***Opinion***

We have audited the financial statements of Beazley Insurance DAC ('the Company') for the year ended 31 December 2018 which comprise the Profit and Loss Account, the Statement of Changes in Equity, the Balance Sheet and related notes, including the summary of significant accounting policies set out in note 1. The financial reporting framework that has been applied in their preparation is Irish Law and FRS 102 *The Financial Reporting Standard applicable in the UK and Republic of Ireland* and FRS 103 *Insurance Contracts*.

In our opinion, the accompanying financial statements:

- give a true and fair view of the assets, liabilities and financial position of the Company as at 31 December 2018 and of its profit for the year then ended;
- have been properly prepared in accordance with FRS 102 *The Financial Reporting Standard applicable in the UK and Republic of Ireland* and FRS 103 *Insurance Contracts*;
- have been properly prepared in accordance with the requirements of the Companies Act 2014; and
- have been properly prepared in accordance with the requirements of the European Union (Insurance Undertakings: Financial Statements) Regulations 2015.

#### ***Basis for opinion***

We conducted our audit in accordance with International Standards on Auditing (Ireland) ("ISAs (Ireland)") and applicable law. Our responsibilities under those standards are further described in the *Auditor's Responsibilities* section of our report. We believe that the audit evidence we have obtained is a sufficient and appropriate basis for our opinion. Our audit opinion is consistent with our report to the Audit Committee.

We were appointed as auditor by the directors on 27 November 2008. The period of total uninterrupted engagement is the 10 years ended 31 December 2018. We have fulfilled our ethical responsibilities under, and we remained independent of the Company in accordance with, ethical requirements applicable in Ireland, including the Ethical Standard issued by the Irish Auditing and Accounting Supervisory Authority (IAASA) as applied to public interest entities. No non-audit services prohibited by that standard were provided.





## Key audit matters: our assessment of risks of material misstatement

Key audit matters are those matters that, in our professional judgment, were of most significance in the audit of the financial statements and include the most significant assessed risks of material misstatement (whether or not due to fraud) identified by us, including those which had the greatest effect on: the overall audit strategy; the allocation of resources in the audit; and directing the efforts of the engagement team. These matters were addressed in the context of our audit of the financial statements as a whole, and in forming our opinion thereon, and we do not provide a separate opinion on these matters.

In arriving at our audit opinion above, the key audit matters, in decreasing order of audit significance, were as follows:

### Valuation of liabilities for claims outstanding \$165.7m and debtors arising from reinsurance operations \$121.2m (2017 - \$2,122.8m and Nil)

*Refer to pages 16 to 18 (accounting policy) and pages 33 to 36 (financial disclosures)*

The key audit matter	How the matter was addressed in our audit
<p>The valuation of liabilities for claims outstanding and debtors arising from reinsurance operations is the most significant inherent risk in our audit.</p>	<p>Our procedures, which were supported by our colleagues in London, including the involvement of actuarial specialists, include but are not limited to:</p>
<p>The level of subjectivity in the estimated impact of uncertain or unknown future events, the diversity of risks insured or reinsured by Beazley Insurance and therefore the level of reserving that occurs at reinsurer level, and the exposure to extreme losses in the catastrophe book serve to increase the level of judgement required and subjectivity inherent in the estimation of liabilities for claims outstanding and debtors arising from reinsurance operations.</p>	<p>Recalculation: Recalculating the Company's share of the underlying syndicate loss (liabilities for claims outstanding) or profit (debtors arising from reinsurance operations) by open contract year of account based on the audited results of the cedant and the terms of the reinsurance agreements.</p>
<p>We identified the valuation of liabilities for claims outstanding as a key audit matter in the prior year. As a result of the new reinsurance agreements entered by the Company during the year, we have also assessed the valuation of debtors arising from reinsurance operations as a key audit matter in the current year.</p>	<p>Re-projections: Comparing actuarial projection of premiums and claims (on a gross and net basis), prepared by our colleagues in London to the cedant's estimates.</p>
	<p>Sector experience and benchmarking: Performing benchmarking of the cedant's ultimate loss ratios, initial expected loss ratios, premium rate change, expectations of total losses on natural catastrophes, the rate at which incurred but not reported reserves have been utilised in the year and reserve releases in comparison to the rest of the market, in order to identify specific trends and outliers.</p>
	<p>Methodology assessment: Assessing the reserving assumptions and methodology (on a gross basis and net of outward reinsurance) for reasonableness.</p>
	<p>Actual versus expected testing: Challenging the quality of historical reserving estimates by monitoring progression of loss ratios against expectations.</p>
	<p>Data reconciliation: Checking the completeness and accuracy of the data used within the reserving process by</p>





reconciling the actuarial source data to the financial systems. Also checking the completeness and accuracy of data flow from the claims and policy systems into the financial systems primarily through the testing of controls.

Based on our assessment of information obtained from our procedures, we considered that the valuation of liabilities for claims outstanding and debtors arising from reinsurance operations was reasonable.

**Ownership and valuation of financial assets \$1,399.6m and financial liabilities \$256.6m (2017 - \$1,234.3m and \$248.9m)**

*Refer to pages 18 to 20 (accounting policy) and pages 31, 32 and 37 (financial disclosures)*

**The key audit matter**

Investments are held to meet the future claims payments and the required capital for the Company

Key judgements relate to the valuation and liquidity of investments and fair value hierarchy classification.

This key audit matter is unchanged from the prior year.

**How the matter was addressed in our audit**

Our procedures, which involve obtaining and assessing testing performed by the our colleagues in London, included but were not limited to:

Reconciliation controls: Testing the design and operating effectiveness of the controls associated with the ownership of investments held.

Valuations: Testing the valuation of debt securities and equity linked funds by agreeing the prices used to independent third party sources using pricing specialists. For investments in hedge funds, inspecting the financial statements of the underlying fund to confirm that the valuation approach was acceptable.

Historical accuracy: For investments in hedge funds assessing historical accuracy of the valuation by comparing interim valuation reports to the final year-end reports for prior period.

Roll forward testing: Assessing the quantum of change in the valuation of investments between the early close date and the period end date to consider whether there is a material movement post the early close date that requires adjustment.

Ownership and existence: Agreeing the investment holdings at year end to independently obtained confirmations.

Based on our assessment of information obtained from our procedures, we considered that the ownership and valuation of financial assets and financial liabilities was reasonable.



## Accounting treatment for new reinsurance contracts

Refer to pages 16 and 17 (accounting policy) and pages 21 to 36 (financial disclosures)

### The key audit matter

This is a new key audit matter for the current year.

There is a risk that the endorsed reinsurance contracts between Beazley Underwriting Limited and the Company are not appropriately accounted for and disclosed in the financial statements in accordance with FRS 102 and FRS 103.

Key judgements relate to:

- Whether the terms and conditions of the new contracts differ in substance from the previous contracts to trigger a review of the accounting treatment;
- The appropriate accounting treatment for the new contracts; and
- Implications of any change in the accounting treatment for existing open contracts.

### How the matter was addressed in our audit

Our procedures include but are not limited to:

Obtaining and reviewing the approved and signed contracts for the 2019 reinsurance agreement and endorsements of open year of account reinsurance agreements to understand the nature of and the terms and conditions of these contracts.

Obtaining and reviewing management's accounting paper setting out the accounting treatment in relation to the reinsurance agreements, including the recognition and presentation of the reinsurance transactions and balances in the Company's primary statements, accounting policies and related disclosures.

With support from our colleagues in London, assessing the appropriateness of this accounting treatment under local statutory and regulatory reporting requirements and vouching the accounting entries to supporting documentation.

Reviewing and assessing the appropriateness of the disclosures made in the financial statements in respect of the reinsurance agreements.

Based on our assessment of information obtained from our procedures, we considered that the accounting treatment was reasonable.

We continue to perform procedures over the valuation of premium estimates. However, as a result of the new reinsurance agreements entered during the year we have not assessed this as one of the most significant risks in our current year audit, and therefore it is not separately identified in our report this year.

### Our application of materiality and an overview of the scope of our audit

Materiality for the financial statements as a whole was set at \$3.9m (2017: \$14.3m). This has been calculated with reference to a benchmark of the Company's profit before tax (of which it represents 8% (2017: 1% of gross written premium)). Due to the new reinsurance agreements and the associated accounting treatment gross written premium is no longer the most appropriate metric therefore the presumed benchmark, profit before tax, is used. We compared our materiality to other relevant benchmarks, such as gross written premium and total assets to ensure the materiality selected was appropriate for our audit.

We reported to the Audit Committee any corrected or uncorrected identified misstatements exceeding \$0.2m (2017: \$0.7m) in addition to other qualitative misstatements that warranted reporting on qualitative grounds.

Our audit of the Company was undertaken to the materiality level specified above and was performed at the Company's head office at 2 Northwood Avenue, Northwood Park, Santry



Demesne, Dublin 1, Ireland and KPMG Offices, 1 Harbourmaster Place, International Financial Services Centre, Dublin 1.

***We have nothing to report on going concern***

We are required to report to you if we have concluded that the use of the going concern basis of accounting is inappropriate or there is an undisclosed material uncertainty that may cast significant doubt over the use of that basis for a period of at least twelve months from the date of approval of the financial statements. We have nothing to report in these respects.

***Other information***

The directors are responsible for the preparation of the other information presented in the Annual Report together with the financial statements. The other information comprises the information included in the report of the directors and directors and advisers sections of the Annual Report.

The financial statements and our auditor's report thereon do not comprise part of the other information. Our opinion on the financial statements does not cover the other information and, accordingly, we do not express an audit opinion or, except as explicitly stated below, any form of assurance conclusion thereon.

Our responsibility is to read the other information and, in doing so, consider whether, based on our financial statements audit work, the information therein is materially misstated or inconsistent with the financial statements or our audit knowledge. Based solely on that work we have not identified material misstatements in the other information.

Based solely on our work on the other information we report that, in those parts of the report of the directors specified for our review:

- we have not identified material misstatements in the report of the directors;
- in our opinion, the information given in the report of the directors is consistent with the financial statements; and
- in our opinion, the report of the directors has been prepared in accordance with the Companies Act 2014.

***Our opinions on other matters prescribed by the Companies Act 2014 are unmodified***

We have obtained all the information and explanations which we consider necessary for the purpose of our audit.

In our opinion, the accounting records of the Company were sufficient to permit the financial statements to be readily and properly audited and the Company's balance sheet and profit and loss account is in agreement with the accounting records.

***We have nothing to report on other matters on which we are required to report by exception***

The Companies Act 2014 requires us to report to you if, in our opinion, the disclosures of directors' remuneration and transactions required by Sections 305 to 312 of the Act are not made.



## **Respective responsibilities and restrictions on use**

### ***Directors' responsibilities***

As explained more fully in their statement set out on page 3, the directors are responsible for: the preparation of the financial statements including being satisfied that they give a true and fair view; such internal control as they determine is necessary to enable the preparation of financial statements that are free from material misstatement, whether due to fraud or error; assessing the Company's ability to continue as a going concern, disclosing, as applicable, matters related to going concern; and using the going concern basis of accounting unless they either intend to liquidate the Company or to cease operations, or have no realistic alternative but to do so.

### ***Auditor's responsibilities***

Our objectives are to obtain reasonable assurance about whether the financial statements as a whole are free from material misstatement, whether due to fraud or error, and to issue our opinion in an auditor's report. Reasonable assurance is a high level of assurance, but does not guarantee that an audit conducted in accordance with ISAs (Ireland) will always detect a material misstatement when it exists. Misstatements can arise from fraud, other irregularities or error and are considered material if, individually or in aggregate, they could reasonably be expected to influence the economic decisions of users taken on the basis of the financial statements. The risk of not detecting a material misstatement resulting from fraud or other irregularities is higher than for one resulting from error, as they may involve collusion, forgery, intentional omissions, misrepresentations, or the override of internal control and may involve any area of law and regulation and not just those directly affecting the financial statements.

A fuller description of our responsibilities is provided on IAASA's website at [https://www.iaasa.ie/getmedia/b2389013-1cf6-458b-9b8f-a98202dc9c3a/Description\\_of\\_auditors\\_responsibilities\\_for\\_audit.pdf](https://www.iaasa.ie/getmedia/b2389013-1cf6-458b-9b8f-a98202dc9c3a/Description_of_auditors_responsibilities_for_audit.pdf).

### ***The purpose of our audit work and to whom we owe our responsibilities***

Our report is made solely to the Company's members, as a body, in accordance with Section 391 of the Companies Act 2014. Our audit work has been undertaken so that we might state to the Company's members those matters we are required to state to them in an auditor's report and for no other purpose. To the fullest extent permitted by law, we do not accept or assume responsibility to anyone other than the Company and the Company's members, as a body, for our audit work, for our report, or for the opinions we have formed.

**Ivor Conlon**  
for and on behalf of  
**KPMG**  
**Chartered Accountants, Statutory Audit Firm**  
1 Harbourmaster Place,  
IFSC,  
Dublin 1, Ireland

**15 April 2019**

# Profit or loss account

for the year ended 31 December 2018

## Technical account – non-life insurance business

	Notes	2018 \$m	2017 \$m
Gross premiums written	3	104.6	1,411.6
Written premiums ceded to reinsurers		(1.1)	(0.2)
<b>Net premiums written</b>		<b>103.5</b>	<b>1,411.4</b>
Change in the gross provision for unearned premiums	13	(5.1)	(77.6)
Reinsurer's share of change in the provision for unearned premium	13	0.6	0.2
<b>Change in net provision for unearned premiums</b>		<b>(4.5)</b>	<b>(77.4)</b>
<b>Net earned premiums</b>	3	<b>99.0</b>	<b>1,334.0</b>
Allocated investment return transferred from the non-technical account	4	31.1	132.7
<b>Revenue</b>		<b>130.1</b>	<b>1,466.7</b>
Gross claims paid		-	(618.7)
Reinsurers' share of claims paid		-	-
<b>Claims paid net of reinsurance</b>		<b>-</b>	<b>(618.7)</b>
Change in gross provision for claims	13	(34.2)	(152.5)
Reinsurer's share of change in provision for claims	13	0.4	-
<b>Change in the net provision for claims</b>		<b>(33.8)</b>	<b>(152.5)</b>
<b>Claims incurred net of reinsurance</b>		<b>(33.8)</b>	<b>(771.2)</b>
Net operating expenses	5	(18.7)	(573.7)
Investment charges transferred from the non-technical account	4	(1.4)	(5.9)
<b>Balance on the technical account</b>		<b>76.2</b>	<b>115.9</b>

## Profit or loss account *continued*

### Non-technical account

	Notes	2018 \$m	2017 \$m
Investment income	4	31.1	132.7
Allocated investment return transferred to the non-life technical account		(31.1)	(132.7)
Investment expenses	4	(1.4)	(5.9)
Allocated investment expenses transferred to the non-life technical account		1.4	5.9
Finance costs		(14.9)	(14.9)
Loss on foreign exchange		(12.3)	(5.2)
<b>Profit on ordinary activities before taxation</b>		<b>49.0</b>	<b>95.8</b>
Tax on profit on ordinary activities	7	(5.2)	(10.4)
<b>Profit for the financial year</b>		<b>43.8</b>	<b>85.4</b>

The company's operating activities all relate to continuing operations.

The company has no recognised gains or losses for the year or in the previous year other than those dealt with in the profit and loss account.

During the year, the reinsurance contracts in place with Beazley Underwriting Limited were endorsed with amended terms in relation to profit retention and excess of loss. Under the new contracts, a single premium or claim balance is recognised under each contract if at the reporting date the underlying result of the syndicates is a profit or a loss (subject to excesses). In this regard, the current year profit or loss account is not directly comparable to prior year comparatives on a line by line basis. Further information on the accounting treatment of the new contracts is presented in the notes on pages 16 to 37 which form part of these financial statements.

# Statement of changes in equity

for the year ended 31 December 2018

	Notes	Capital contribution \$m	Foreign exchange reserve \$m	Retained earnings \$m	Total equity \$m
Balance as at 1 January 2018		536.3	(42.8)	627.3	1,120.8
Profit for the financial year		-	-	43.8	43.8
Dividend paid	12	-	-	(78.0)	(78.0)
<b>Balance as at 31 December 2018</b>		<b>536.3</b>	<b>(42.8)</b>	<b>593.1</b>	<b>1,086.6</b>

	Notes	Capital contribution \$m	Foreign exchange reserve \$m	Retained earnings \$m	Total equity \$m
Balance as at 1 January 2017		536.3	(42.8)	622.8	1,116.3
Profit for the financial year		-	-	85.4	85.4
Dividend paid	12	-	-	(80.9)	(80.9)
<b>Balance as at 31 December 2017</b>		<b>536.3</b>	<b>(42.8)</b>	<b>627.3</b>	<b>1,120.8</b>

The notes on pages 16 to 37 form part of these financial statements.



# Balance sheet

as at 31 December 2018

	Notes	2018 \$m	2017 \$m
<b>Assets</b>			
<b>Fixed assets</b>			
Leasehold improvements		-	0.2
		-	0.2
<b>Investments</b>			
Financial assets designated at fair value through profit or loss	2, 8	1,399.6	1,234.3
		1,399.6	1,234.3
<b>Reinsurer's share of technical provision</b>			
Provision for unearned premiums, reinsurer's share	13	0.7	0.2
Claims outstanding, reinsurer's share	13	0.5	-
		1.2	0.2
<b>Debtors</b>			
Amounts due from group companies		-	2,729.7
Debtors arising from direct insurance operations		4.3	0.5
Debtors arising from reinsurance operations	14	121.2	-
Current tax receivable	9	5.3	7.7
		130.8	2,737.9
<b>Cash and cash equivalents</b>	10	20.9	23.1
<b>Prepayments and accrued income</b>			
Deferred acquisition costs	11	1.4	234.2
Other prepayments and accrued interest		8.7	4.3
		10.1	238.5
<b>Total assets</b>		1,562.6	4,234.2

Balance sheet *continued*

	Notes	2018 \$m	2017 \$m
<b>Equity</b>			
<b>Capital and reserves</b>			
Called up share capital – presented as equity	12	-	-
Capital contribution	12	536.3	536.3
Foreign exchange translation reserve	12	(42.8)	(42.8)
Profit or loss account		593.1	627.3
<b>Shareholders' funds attributable to equity interests</b>		<b>1,086.6</b>	<b>1,120.8</b>
<b>Liabilities</b>			
<b>Technical provisions</b>			
Provision for unearned premium	13	5.4	737.7
Claims outstanding	13	165.7	2,122.8
		<b>171.1</b>	<b>2,860.5</b>
<b>Creditors</b>			
Amounts due to group companies		43.2	-
Other creditors		5.1	4.0
		<b>48.3</b>	<b>4.0</b>
<b>Financial liabilities</b>	2, 8, 19	<b>256.6</b>	<b>248.9</b>
<b>Total liabilities</b>		<b>476.0</b>	<b>3,113.4</b>
<b>Total equity and liabilities</b>		<b>1,562.6</b>	<b>4,234.2</b>

Approved on behalf of the board of directors:

Catherine Woods  
Director

Ed McGivney  
Director

15 April 2019

During the year, the reinsurance contracts in place with Beazley Underwriting Limited were endorsed with amended terms in relation to profit retention and excess of loss. Under the new contracts, a single premium or claim balance is recognised under each contract if at the reporting date the underlying result of the syndicates is a profit or a loss (subject to excesses). In this regard, the current year balance sheet is not directly comparable to prior year comparatives on a line by line basis. Further information on the accounting treatment of the new contracts is presented in the notes on pages 16 to 37 which form part of these financial statements.

# Notes to the financial statements

for the year ended 31 December 2018

## 1 Principal accounting policies

The following accounting policies have been applied consistently in dealing with items which are considered material in relation to the financial statements.

### (a) Basis of preparation

The financial statements have been prepared in accordance with Financial Reporting Standard 102, (*the Financial Reporting Standard applicable in the UK and Republic of Ireland*) (FRS 102) and Financial Reporting Standard 103 (*Insurance Contracts*) (FRS 103).

The financial statements of Beazley Insurance dac have been prepared on a going concern basis. The directors of the company have a reasonable expectation that the company has adequate resources to continue in operational existence for the foreseeable future.

The financial statements comply with the European Union (Insurance Undertakings: Financial Statements) Regulations 2015, and the Companies Act 2014.

Under FRS 102.1.12(b), the company is exempt from the requirement to prepare a cash flow statement on the grounds that a parent undertaking includes the company in its own published consolidated financial statements.

As 100% of the voting rights of the company are controlled within the group headed by Beazley plc, the company has taken advantage of the exemption contained in FRS 102.33.1A and has therefore not disclosed transactions or balances with entities which form part of the group. The consolidated financial statements of Beazley plc, within which this company is included, can be obtained from the registered address listed on page 37 of these accounts.

### (b) Basis of accounting for insurance/reinsurance activities

As noted on page 2, the company undertakes both insurance and reinsurance activities. The company writes direct insurance through a network of EU branches and has an aggregate excess of loss reinsurance agreement with Beazley Underwriting Limited. During 2018, the terms of the reinsurance agreement were amended leading to the endorsement of the open year contracts in place. The amended terms increased the excess from £2m to \$4m in respect of losses, and added a profit retention of \$4m.

Under the terms of the endorsed agreements the company reinsures and indemnifies Beazley Underwriting Limited in respect of all losses up to 75% of the declared result of Beazley Underwriting Limited's participation in syndicates 2623 and 3623 (subject to a \$4m excess). In the event that the declared result is a loss, the extent of the reinsurance is limited to the loss in excess of \$4m not exceeding 75% of the Funds at Lloyds. The underwriting results relating to this reinsurance contract are determined on an annual basis. Results under this contract reported on an annual basis recognise profits or losses as they are earned instead of at the closure of a particular Lloyd's year of account, normally after three years.

The accounting treatment for the new reinsurance arrangements is different to the accounting treatment under the previous reinsurance contracts. In the prior year, the results of the reinsurance contract were presented in the profit or loss account on a line by line basis, reflecting the company's precise proportional share of the syndicate business. In the current year, the excess of loss cede is reflected in the profit or loss account in accordance with the definition of premium and the limits of liability contained in the excess of loss agreement. This treatment results in each contract being accounted for as either a single premium or outstanding claim balance depending on whether the declared result of the syndicates is a profit or a loss. In this regard, the company will recognise a premium receivable when an underlying reinsurance contract is in a profitable position at the reporting date, and will show an outstanding claim reserve when an underlying contract is in a loss making position at the reporting date. Movements in premium receivables and outstanding claims reserves will be shown through the profit and loss account and outlined in further detail through the notes to the financial statements. The effect of the transition to accounting for the new reinsurance contracts is further documented in note 13 and note 15 of the financial statements.

As the premium/claim balance presented in the profit or loss account represents the company's share of the profit or loss before tax of the syndicates, premium earnings adjustments and expense deferrals in respect of the underlying syndicate business have already been recognised through the premium or claims recognised under the contract. In this regard, the company's balance sheet no longer contains technical balances such as deferred acquisition costs and the provision for unearned premium relating to the reinsurance contracts.

## 1 Principal accounting policies *continued*

### (b) Basis of accounting for insurance activities *continued*

These changes were enacted from 1 January 2018 and therefore have been applied prospectively in accordance with FRS 102; meaning the prior year profit or loss account, balance sheet and certain notes to the financial statements are not directly comparable to current year balances on a line by line basis. The non-comparability of balances disclosed is further disclosed, where applicable, in the notes to the financial statements.

#### *Premiums*

Gross premiums written represent:

- premium as defined in the aggregate excess of loss reinsurance agreement (see note 1(b) above) with Beazley Underwriting Limited.
- direct insurance premiums written through branches located in the EU.

For completeness, a premium is recognised by the company under a reinsurance contract if at the reporting date, the underlying result of the syndicates is a profit (and in excess of \$4m). If the underlying result of the syndicate is loss making at the reporting date, only a minimum premium of £100 will be recognised. In the prior year, premium recognised under a reinsurance contract represented a 75% share of premiums notified as due to the syndicates.

In relation to direct insurance, gross premiums written are stated before deduction of commissions but exclusive of taxes, duties levied on premiums and other deductions; and outward reinsurance premiums are accounted for in the same accounting period as the related direct insurance or inwards reinsurance business except in relation to excess of loss contracts, where the initial premium is charged when paid.

Unearned premiums represent the proportion of direct insurance premiums written which is estimated to be earned in the following or subsequent financial periods, computed separately for each insurance contract using the daily pro rata method, adjusted if necessary to reflect any variation in the incidence of risk during the period covered by the contract.

#### *Claims incurred*

Claims incurred represent all claims payments and internal and external settlement expense payments made by the company in the financial year and the movement in the provisions for outstanding claims and settlement expenses, including claims incurred but not reported, net of salvage and subrogation expenses. Where appropriate, statistical methods have been applied to past experience of claims frequency and severity. Included in the movement in the provision for outstanding claims is the movement in claims reserves relevant to the reinsurance contracts with Beazley Underwriting Limited, as defined by the aggregate excess of loss agreement (see note 1(b) above) with that company.

Due to the accounting treatment of these new reinsurance contracts driven by the 2018 endorsements, the claims incurred balance reported in the profit or loss account is not directly comparable with prior year balances. In the prior year claims incurred under the reinsurance contracts with Beazley Underwriting Limited represented a 75% share of all claims payments and a 75% share in the movement in the provisions for outstanding claims in the syndicates.

#### *Claims provisions*

Provision is made at the year-end for the estimated cost of claims incurred but not settled at the balance sheet date, including the cost of claims incurred but not yet reported to the company. The estimated cost of claims includes expenses to be incurred in settling claims and a deduction for the expected value of salvage and other recoveries. The company takes all reasonable steps to ensure that it has appropriate information regarding its claims exposures. However, given the uncertainty in establishing claims provisions, it is likely that the final outcome will prove to be different from the original liability established.

The estimation of claims incurred but not reported (IBNR) is generally subject to a greater degree of uncertainty than the estimation of the cost of settling claims already notified to the company, where more information about the claim event is generally available. Claims IBNR may often not be apparent to the insured until many years after the event giving rise to the claims has happened. Classes of business where the IBNR proportion of the total reserve is high will typically display greater variations between initial estimates and final outcomes because of the greater degree of difficulty of estimating these reserves. Classes of business where claims are typically reported relatively quickly after the claim event tend to display lower levels of volatility.

A component of these estimation techniques is usually the estimation of the cost of notified but not paid claims. In estimating the cost of these the company has regard to the claim circumstance as reported, any information available from loss adjusters and information on the cost of settling claims with similar characteristics in previous periods.

## Notes to the financial statements *continued*

### 1 Principal accounting policies *continued*

#### (b) Basis of accounting for insurance activities *continued*

Large claims impacting each relevant business class are generally assessed separately, being measured on a case by case basis or projected separately in order to allow for the possible distortive effect of the development and incidence of these large claims.

Where possible the company adopts multiple techniques to estimate the required level of provisions. This assists in giving greater understanding of the trends inherent in the data being projected. The projections given by the various methodologies also assist in setting the range of possible outcomes. The most appropriate estimation technique is selected taking into account the characteristics of the business class and the extent of the development of each accident year.

Claims provisions include claims reserves as calculated in accordance with the definition of the limit of liability contained in the aggregate excess of loss agreement with Beazley Underwriting Limited. To the extent that a claim provision is recognised on an open contract at the reporting period, it is reflected as an outstanding claim reserve, which may increase or decrease depending on the final declared results of the syndicates under the relevant reinsurance contracts. In the prior year claims provisions represented 75% of the claims provisions as calculated by the syndicates.

Claims provisions are also recognised for direct insurance written through branches in the EU, net of any estimates of amounts that will be recoverable from reinsurers having due regard to collectability.

#### *Deferred acquisition costs*

Deferred acquisition costs represent the deferral of costs of writing premium through branches in the EU.

Acquisition costs incurred comprise brokerage, premium levy and staff-related costs of underwriters acquiring new business and renewing existing contracts. The proportion of acquisition costs in respect of unearned premiums is deferred at the balance sheet date and recognised in later periods when the related premiums are earned.

Due to the accounting treatment of the new reinsurance contracts driven by the endorsements which took place in 2018, deferred acquisition costs relevant to these contracts are no longer recognised on the balance sheet and therefore this balance is not directly comparable with prior year balances. In the prior year deferred acquisition costs relevant to the reinsurance contracts represented a 75% share of the deferred acquisition costs of the syndicates.

#### *Use of estimates and judgements*

The preparation of financial statements requires management to make judgements, estimates and assumptions that affect the application of accounting policies and reported amounts of assets, liabilities, income and expenses. Actual results may differ from these estimates.

Estimates and underlying assumptions are reviewed on an ongoing basis. Revisions to accounting estimates are recognised in the period in which the estimate is revised and in any future periods affected.

The most critical estimates included within the company's financial statements are the estimates for the fair value of investments and the estimate of the premium receivable or claims provision arising under the reinsurance contracts. Further information about our investment portfolio can be found at note 2 and note 8 of the financial statements. Information on the premium receivable and claims provisions under the reinsurance contracts can be found at notes 13 and 14.

#### (c) Financial instruments

Financial instruments are recognised in the balance sheet at such time that the company becomes a party to the contractual provisions of the financial instrument. A financial asset is derecognised when the contractual rights to receive cash flows from the financial assets expire, or where the financial assets have been transferred, together with substantially all the risks and rewards of ownership. Financial liabilities are derecognised if the company's obligations specified in the contract expire, are discharged or cancelled. Purchases and sales of financial assets are recognised on the trade date, which is the date the company commits to purchase or sell the asset.

#### *Financial assets and liabilities*

On acquisition of a financial asset and liabilities, the company is required to classify the assets and liabilities into the following categories: financial assets and liabilities at fair value through profit or loss, loans and receivables, held to maturity and available for sale. The company does not make use of the held to maturity and available for sale classifications.

## 1 Principal accounting policies *continued*

### (c) Financial instruments *continued*

#### *Financial assets and liabilities at fair value through profit or loss*

This category has two sub-categories: financial assets and liabilities held for trading and those designated at fair value through profit or loss at inception.

Financial assets and liabilities held for trading are those assets which are acquired principally for the purpose of selling in the short term, or which are held as part of a portfolio in which there is evidence of short-term profit taking or if it is designated so by management. At present all derivatives are classified as held for trading by the company.

All non-derivative financial investments are designated as fair value through profit or loss upon initial recognition because their performance is evaluated on a fair value basis. Information about these financial assets is provided internally on a fair value basis to key management. The investment strategy is to invest and evaluate their performance with reference to their fair values.

#### *Fair value measurement*

Fair value is the amount for which an asset and liability could be exchanged, or a liability settled, between knowledgeable, willing parties in an arm's length transaction on the measurement date.

When available, the company measures the fair value of an instrument using quoted prices in an active market for that instrument. A market is regarded as active if quoted prices are readily and regularly available and represent actual and regularly occurring market transactions on an arm's length basis.

If a market for a financial instrument is not active, the company establishes fair value using a valuation technique. Valuation techniques include using recent arm's length transactions between knowledgeable, willing parties (if available), reference to the current fair value of other instruments that are substantially the same, discounted cash flow analyses and option pricing models. The chosen valuation technique makes maximum use of market inputs, relies as little as possible on estimates specific to the company, incorporates all factors that market participants would consider in setting a price, and is consistent with accepted economic methodologies for pricing financial instruments. Inputs to valuation techniques reasonably represent market expectations and measures of the risk-return factors inherent in the financial instrument. The company calibrates valuation techniques and tests them for validity using prices from observable current market transactions in the same instrument or based on other available observable market data.

The best evidence of the fair value of a financial instrument at initial recognition is the transaction price, i.e., the fair value of the consideration given or received, unless the fair value of that instrument is evidenced by comparison with other observable current market transactions in the same instrument (i.e., without modification or repackaging) or based on a valuation technique whose variables include only data from observable markets. When transaction price provides the best evidence of fair value at initial recognition, the financial instrument is initially measured at the transaction price and any difference between this price and the value initially obtained from a valuation model is subsequently recognised in profit or loss depending on the individual facts and circumstances of the transaction but not later than when the valuation is supported wholly by observable market data or the transaction is closed out.

Assets and long positions are measured at a bid price; liabilities and short positions are measured at an asking price. Where the company has positions with offsetting risks, mid-market prices are used to measure the offsetting risk positions and a bid or asking price adjustment is applied only to the net open position as appropriate. Fair values reflect the credit risk of the instrument and include adjustments to take account of the credit risk of the company and counterparty where appropriate. Fair value estimates obtained from models are adjusted for any other factors, such as liquidity risk or model uncertainties, to the extent that the company believes a third-party market participant would take them into account in pricing a transaction.

Upon initial recognition, attributable transaction costs relating to financial instruments at fair value are recognised in profit or loss account when incurred. Financial assets at fair value through profit or loss are measured at fair value, and changes therein are recognised in the profit and loss account. Net changes in the fair value of financial assets at fair value through profit or loss exclude interest and dividend income.

## Notes to the financial statements *continued*

### 1 Principal accounting policies *continued*

#### (c) Financial instruments *continued*

##### *Investment income*

Investment income consists of dividends, interest, realised and unrealised gains and losses and foreign exchange gains and losses on financial assets or liabilities at fair value through profit or loss. Interest is recognised on an accruals basis for financial assets or liabilities at fair value through profit or loss. The realised gains or losses on disposal of an investment are the difference between the proceeds and the original cost of the investment. Unrealised investment gains and losses represent the difference between the carrying value at the balance sheet date, and the carrying value at the previous year end or purchase value during the year.

In prior years, investment income reported in the profit or loss account included the company's share of the investment income of the syndicates, ceded as part of the reinsurance agreement with Beazley Underwriting Limited. Due to the accounting treatment of the new reinsurance contracts, as a result of the 2018 endorsements, investment income earned by the syndicates is reflected as part of either the premium or claim under the relevant reinsurance contract(s) (depending on whether each individual contract is profit making or loss making at a given point in time). In this regard, investment income in the profit or loss account of the company represents investment income earned directly by the company and includes no share of syndicate investment income.

##### *Derivative financial instruments*

Derivatives are initially recognised at fair value on the date on which a derivative contract is entered into and are subsequently re-measured at their fair value. Fair values are obtained from quoted market prices in active markets, recent market transactions, and valuation techniques which include discounted cash flow models. All derivatives are carried as assets when fair value is positive and as liabilities when fair value is negative. The best evidence of fair value of a derivative at initial recognition is the transaction price.

##### *Borrowings*

Borrowings are initially recorded at fair value less transaction costs incurred. Subsequently borrowings are stated at amortised cost and interest is recognised in the profit or loss account over the period of the borrowings using the effective interest method.

#### (d) Cash and cash equivalents

This consists of cash at bank and in hand and short term deposits held at call with banks.

#### (e) Other payables

Other payables are stated at amortised cost.

#### (f) Taxation

The charge for taxation is based on the profit for the year and takes into account taxation deferred because of timing differences between the treatment of certain items for taxation and accounting purposes.

Current tax is provided on the company's taxable profits at amounts expected to be paid using the tax rates and laws that have been enacted or substantially enacted by the balance sheet date.

#### (g) Foreign currency translation

Transactions in foreign currencies are translated to the company's functional currency at the foreign exchange rate ruling at the date of the transaction. Monetary assets and liabilities denominated in foreign currencies at the balance sheet date are retranslated to the functional currency at the foreign exchange rate ruling at that date. Non-monetary assets and liabilities that are measured in terms of historical cost in a foreign currency are translated using the exchange rate at the date of the transaction.

Non-monetary assets and liabilities denominated in foreign currencies that are stated at fair value are retranslated to the functional currency at foreign exchange rates ruling at the dates the fair value was determined. Foreign exchange differences arising on translation are recognised in the profit or loss account. For the purpose of foreign currency translation, unearned premiums and deferred acquisition costs are treated as if they are monetary items.

The results and financial position of foreign operations that have a functional currency different from the company's presentational currency are translated into the presentational currency as follows:

- assets and liabilities are translated at the closing rate ruling at the balance sheet date;
- income and expenses for each profit or loss account are translated at average exchange rates for the reporting period where this is determined to be a reasonable approximation of the actual transaction rates; and
- all resulting exchange differences are recognised in other comprehensive income and as a separate component of equity.



## 1 Principal accounting policies *continued*

### (g) Foreign currency translation *continued*

Due to the accounting treatment of the new reinsurance contracts with Beazley Underwriting Limited, driven by the 2018 endorsements, the foreign exchange gain/(loss) reported in the profit or loss account is not directly comparable to prior year balances. In the prior year, the company's share of the syndicates foreign exchange gain/(loss) was combined with the company's own foreign exchange gain/(loss) and displayed as a foreign exchange gain/(loss) in the profit or loss account. In 2018, with the new reinsurance contracts, the gain/(loss) is included in the declared result of the syndicates which is presented as a premium or claim in the profit or loss account as further explained above.

## 2 Risk review

The company has identified the risks arising from its activities and has established policies and procedures to manage these items in accordance with its risk appetite. The sections below outline the company's risk appetite and explain how it defines and manages each category of risk.

### *Risk management framework*

#### Corporate governance

The board gives high priority to risk management and risk control. Procedures are in place within the company to ensure that risks are being measured, monitored and reported adequately and effectively to the board risk committee. The company is subject to regular internal audit review which is carried out by the group internal audit function.

#### Capital management

The company is required to maintain minimum capital requirements as set out in the European Union (Insurance and Reinsurance) Regulations 2015 (S.I. 485/2015). Regulations stipulate that the company should maintain capital, allowable for solvency purposes, of at least the calculated threshold amount. At no time in the year has the company failed to meet this requirement.

#### 2.1 Insurance risk

The insurance risk exposure is documented in the business plan which is approved by the board and used to guide current activities and any future developments.

##### *a) Underwriting risk*

Underwriting risk comprises four elements that apply to all insurance products offered by the company:

- cycle risk – the risk that business is written without full knowledge as to the (in)adequacy of rates, terms and conditions;
- event risk – the risk that individual risk losses or catastrophes lead to claims that are higher than anticipated in plans and pricing;
- pricing risk – the risk that the level of expected loss is understated in the pricing process; and
- expense risk – the risk that the allowance for expenses and inflation in pricing is inadequate.

The board reviews detailed underwriting information relating to the syndicate business reinsured by the company through its excess of loss arrangements with Beazley Underwriting Limited. The below section provides an overview of the underwriting risk associated with the underlying syndicate business as well as the insurance business underwritten directly by the company through its specialty lines division. This reflects how the board monitors and manages the business and the associated risks. While the presentation within the financial statements is not consistent relative to the prior year, the underlying risk profile of the company is materially consistent year on year. It is on this basis that additional information in respect of the underlying syndicate business is provided.

The company's underwriting strategy is to seek a diverse and balanced portfolio of risks in order to limit the variability of outcomes. This is achieved by accepting a spread of business over time, segmented between different products, geography and size. The annual business plans for each underwriting team reflect the company's underwriting strategy, and set out the classes of business, the territories and the industry sectors in which business is to be written. These plans are approved by the board of Beazley Furlonge Limited, for syndicate business, and by the board of Beazley Insurance dac for insurance business. These plans are monitored by the monthly Beazley Furlonge Limited underwriting committee and the Beazley Insurance dac insurance underwriting group and the quarterly Beazley Insurance dac reinsurance underwriting group.

The company's underwriters calculate premiums for risks written based on a range of criteria tailored specifically to each individual risk. These factors include but are not limited to the financial exposure, loss history, risk characteristics, limits, deductibles, terms and conditions and acquisition expenses. The company also recognises that insurance events are, by their nature, random, and the actual number and size of events during any one year may vary from those estimated using established statistical techniques.

## Notes to the financial statements *continued*

### 2 Risk review *continued*

#### 2.1 Insurance risk *continued*

To address this, the company sets out the exposure that it is prepared to accept in certain territories to a range of events such as natural catastrophes and specific scenarios which may result in large industry losses. This is monitored through regular calculation of realistic disaster scenarios (RDS). The aggregate position is monitored at the time of underwriting a risk, and reports are regularly produced to highlight the key aggregations to which the company is exposed.

The company uses a number of modelling tools to monitor its exposures against the agreed risk appetite set and to simulate catastrophe losses in order to measure the effectiveness of its reinsurance programmes.

Stress and scenario tests are also run using these models. The range of scenarios considered include natural catastrophes, cyber, marine, liability, political, terrorism and war events.

One of the largest types of event exposure relates to natural catastrophe events such as windstorm or earthquake. Where possible the company measures geographic accumulations and uses its knowledge of the business, historical loss behaviour and commercial catastrophe modelling software to assess the expected range of losses at different return periods. Upon application of the reinsurance coverage purchased, the key gross and net exposures are calculated on the basis of extreme events at a range of return periods.

The company also has exposure to man-made claim aggregations, such as those arising from terrorism and data breach events.

The company chooses to underwrite data breach insurance within the specialty lines division and indirectly through the reinsurance contract with Beazley Underwriting Limited using its team of specialist underwriters, claims managers and data breach services managers. Other than for data breach, the company's preference is to exclude cyber exposure where possible.

To manage the potential exposure, the company's board has established a risk budget for the aggregation of data breach related claims which is monitored by reference to the largest of nine realistic disaster scenarios that have been developed internally. These scenarios have been peer reviewed by an external technical expert and include the failure of a data aggregator, the failure of a shared hardware or software platform and the failure of a cloud provider. Whilst it is not possible to be precise, as there is sparse data on actual aggregated events, these severe scenarios are expected to be very infrequent. It is expected that reinsurance purchased by Beazley entities, whether directly by the company or indirectly by syndicates 2623 and 3623, would mitigate the cost of most, but not all, data breach catastrophes.

In 2018, the company reported gross premiums written of \$104.6m. Of this, 8% (\$8.2m) related to the company's insurance activities (all within the specialty lines division) with the remaining 92% (\$96.4m) being reported under the company's reinsurance activities.

#### *b) Claims management risk*

Similar to section 2.1(a) above, the following section provides an overview of the claims management processes carried out by the company in respect of its direct insurance business, as well as the processes carried out at a syndicate level in respect of the business covered by the company's reinsurance contract with Beazley Underwriting Limited.

Claims management risk may arise within the company in the event of inaccurate or incomplete case reserves and claims settlements, poor service quality or excessive claims handling costs. These risks may damage the Beazley brand and undermine its ability to win and retain business or incur punitive damages. These risks can occur at any stage of the claims life-cycle.

Beazley's claims teams are focused on delivering quality, reliability and speed of service to both internal and external clients. Their aim is to adjust and process claims in a fair, efficient and timely manner, in accordance with the policy's terms and conditions, the regulatory environment, and the business's broader interests. Prompt and accurate case reserves are set for all known claims liabilities, including provisions for expenses.

## 2 Risk review *continued*

### 2.1 Insurance risk *continued*

#### c) Reserving and ultimate reserves risk

Reserving and ultimate reserves risk occurs where established insurance liabilities are insufficient through inaccurate forecasting, or where there is adequate allowance for expenses and reinsurance bad debts in provisions.

To manage reserving and ultimate reserves risk, our actuarial team uses a range of recognised techniques to project gross premiums written, monitor claims development patterns and stress test ultimate insurance liability balances. An external independent actuary also performs an annual review to produce a statement of actuarial opinion for the syndicates (a significant element of this business being ultimately reinsured to Beazley Insurance dac).

The objective of the company's reserving policy is to produce accurate and reliable estimates that are consistent over time and across classes of business. The estimates of gross premiums written and claims prepared by the actuarial department are used through a formal quarterly peer review process to independently test the integrity of the estimates produced by the underwriting teams for each class of business. These meetings are attended by senior management, senior underwriters, actuarial, claims, and finance representatives.

In accordance with the terms of the new reinsurance contracts, the company records an outstanding claim reserve in respect of any open year reinsurance contract with Beazley Underwriting Limited which, at the reporting date, is in a loss making position for the company. Further information in relation to the claims recorded under these contracts is provided in note 1 and note 13 to the financial statements. A five percent increase or decrease in total claims liabilities would have the following effect on profit or loss and equity<sup>1</sup>:

Sensitivity to insurance risk (claims reserves)	5% increase in claims reserves		5% decrease in claims reserves	
	2018 \$m	2017 \$m	2018 \$m	2017 \$m
<b>Impact on profit</b>	<b>(7.2)</b>	<b>(92.9)</b>	<b>7.2</b>	<b>92.9</b>

<sup>1</sup> Due to the accounting treatment of the new reinsurance contracts with Beazley Underwriting Limited, driven by the 2018 endorsements, the prior year balances disclosed in this table are not directly comparable to current year balances. See note 1 for further details.

The company also monitors its exposure to insurance risk by location. All risks underwritten by the company are located in Europe.

### 2.2 Market risk

Market risk arises where the value of assets and liabilities changes as a result of movements in foreign exchange rates, interest rates and market prices.

#### *Foreign exchange risk*

The functional and reporting currency of the company is US dollar. Therefore, the foreign exchange risk is that the company is exposed to fluctuations in exchange rates for any non-dollar denominated transactions and net assets. However foreign exchange risk is actively managed as described below. The company is exposed to changes in the value of assets and liabilities due to movements in foreign exchange rates. The company deals in four main currencies, US dollars, UK sterling, Canadian dollars and Euro. Transactions in all non-dollar currencies are converted to US dollars on initial recognition and revalued at the reporting date.

In 2018, the company managed its foreign exchange risk by periodically assessing its non-dollar exposures and hedging these to a tolerable level while targeting net assets to be predominantly US dollar denominated. On a forward looking basis an assessment is made of expected future exposure development and appropriate currency trades put in place to reduce risk.

The following table summarises the carrying value of net assets categorised by currency:

Net assets by currency	UK £ \$m	CAD \$ \$m	EUR € \$m	Subtotal \$m	US \$ \$m	Total \$m
31 December 2018	195.5	(21.3)	(5.6)	168.6	918.0	1,086.6
31 December 2017	212.0	0.8	28.4	241.2	879.6	1,120.8

## Notes to the financial statements *continued*

### 2 Risk review *continued*

#### 2.2 Market risk *continued*

As part of this hedging strategy, exchange rate derivatives were used to rebalance currency exposure across the company. On a forward looking basis an assessment is made of expected future exposure development and appropriate currency trades put in place to reduce risk. The company's assets are matched by currency to the principal underlying currencies of its insurance liabilities. This helps mitigate the risk that the company's assets required to cover its insurance liabilities are not materially affected by any future movements in exchange rates. Fluctuations in the company's trading currencies against the US dollar would result in a change to net asset value. The table below gives an indication of the impact on net assets of a % change in relative strength of US dollar against the value of sterling, Canadian dollar and euro, simultaneously. The analysis is based on the current information available and is presented net of the impact of the exchange rate derivatives referenced above.

	Impact on profit after tax for the year ended		Impact on net assets	
	2018 \$m	2017 \$m	2018 \$m	2017 \$m
<b>Change in exchange rate of UK Sterling, Canadian dollar and Euro relative to US dollar</b>				
Dollar weakens 30% against other currencies	44.3	63.3	44.3	63.3
Dollar weakens 20% against other currencies	29.5	42.2	29.5	42.2
Dollar weakens 10% against other currencies	14.8	21.1	14.8	21.1
Dollar strengthens 10% against other currencies	(14.8)	(21.1)	(14.8)	(21.1)
Dollar strengthens 20% against other currencies	(29.5)	(42.2)	(29.5)	(42.2)
Dollar strengthens 30% against other currencies	(44.3)	(63.3)	(44.3)	(63.3)

#### *Interest rate risk*

Some of the company's financial instruments, including financial investments, are exposed to movements in market interest rates. The company manages interest rate risk by primarily investing in short duration financial investments. The board of Beazley Insurance dac monitors the duration of these assets on a regular basis.

The following table shows the average duration at the reporting date of the financial instruments. Duration is a commonly used measure of volatility and we believe gives a better indication than maturity of the likely sensitivity of our portfolio to changes in interest rates.

#### Duration

	<1 yr \$m	1-2 yrs \$m	2-3 yrs \$m	3-4 yrs \$m	4-5 yrs \$m	5-10 yrs \$m	>10 yrs \$m	Total \$m
<b>31 December 2018</b>								
Fixed and floating rate securities	400.0	229.2	397.5	157.6	69.7	42.1	-	1,296.1
Cash and cash equivalents	20.9	-	-	-	-	-	-	20.9
Derivative financial instruments	(6.9)	-	-	-	-	-	-	(6.9)
Borrowings	-	-	-	-	-	(248.7)	-	(248.7)
<b>Total</b>	<b>414.0</b>	<b>229.2</b>	<b>397.5</b>	<b>157.6</b>	<b>69.7</b>	<b>(206.6)</b>	<b>-</b>	<b>1,061.4</b>
<b>31 December 2017</b>								
Fixed and floating rate securities	412.1	259.1	200.3	120.5	107.5	-	-	1,099.5
Cash and cash equivalents	23.1	-	-	-	-	-	-	23.1
Derivative financial instruments	4.6	-	-	-	-	-	-	4.6
Borrowings	-	-	-	-	-	(248.5)	-	(248.5)
<b>Total</b>	<b>439.8</b>	<b>259.1</b>	<b>200.3</b>	<b>120.5</b>	<b>107.5</b>	<b>(248.5)</b>	<b>-</b>	<b>878.7</b>

In November 2016, the company issued \$250m of subordinated tier 2 notes due in 2026. Annual interest, at a fixed rate of 5.875%, is payable in May and November each year.

## 2 Risk review *continued*

### 2.2 Market risk *continued*

#### *Sensitivity analysis*

The company holds financial assets and liabilities that are exposed to interest rate risk. Changes in interest yields, with all other variables constant, would result in changes in the capital value of debt securities and a change in value of borrowings and derivative financial instruments. This will affect reported profits and net assets as indicated in the below table:

	Impact on profit after tax for the year ended		Impact on net assets	
	2018 \$m	2017 \$m	2018 \$m	2017 \$m
<b>Shift in yield (basis points)</b>				
150 basis point increase	(32.9)	(24.6)	(32.9)	(24.6)
100 basis point increase	(21.9)	(16.4)	(21.9)	(16.4)
50 basis point increase	(11.0)	(8.2)	(11.0)	(8.2)
50 basis point decrease	11.0	8.2	11.0	8.2
100 basis point decrease	21.9	16.4	21.9	16.4

#### *Price risk*

Debt securities and equities that are recognised on the balance sheet at their fair value are susceptible to losses due to adverse changes in prices. This is referred to as price risk. Investments are made in debt securities and equities depending on the company's appetite for risk. These investments are well diversified with high quality, liquid securities. The board has established comprehensive guidelines with investment managers setting out maximum investment limits, diversification across industries and concentrations in any one industry or company.

Listed investments are recognised on the balance sheet at quoted bid price. If the market for the investment is not considered to be active, then the company establishes fair value using valuation techniques. This includes using recent arm's length market transactions, reference to current fair value of other investments that are substantially the same, discounted cash flow models and other valuation techniques that are commonly used by market participants.

	Impact on profit after tax for the year ended		Impact on net assets	
	2018 \$m	2017 \$m	2018 \$m	2017 \$m
30% increase in fair value	26.9	34.1	26.9	34.1
20% increase in fair value	17.9	22.7	17.9	22.7
10% increase in fair value	9.0	11.4	9.0	11.4
10% decrease in fair value	(9.0)	(11.4)	(9.0)	(11.4)
20% decrease in fair value	(17.9)	(22.7)	(17.9)	(22.7)
30% decrease in fair value	(26.9)	(34.1)	(26.9)	(34.1)

### 2.3 Liquidity risk

Liquidity risk arises where cash may not be available to pay obligations when due at a reasonable cost. The company's approach is to manage its liquidity position so that it can reasonably survive a significant individual or market loss event. This means that the company maintains sufficient liquid assets, or assets that can be translated into liquid assets at short notice and without any significant capital loss, to meet expected cash flow requirements. These liquid funds are regularly monitored using cash flow forecasting to ensure that surplus funds are invested to achieve a higher rate of return.

Notes to the financial statements *continued***2 Risk review** *continued***2.3 Liquidity risk** *continued*

The following is an analysis by business segment of the estimated timing of the net cash flows based on the net claims liabilities balance held at 31 December 2018 and 31 December 2017<sup>1</sup>:

	Within 1 year \$m	1-3 years \$m	3-5 years \$m	Greater than 5 years \$m	Total \$m	Weighted average term to settlement (years)
<b>31 December 2018</b>						
Specialty lines	0.3	0.6	0.4	0.4	1.7	3.5
Reinsurance	-	163.5	-	-	163.5	1.5
<b>Net insurance liabilities</b>	<b>0.3</b>	<b>164.1</b>	<b>0.4</b>	<b>0.4</b>	<b>165.2</b>	

	Within 1 year \$m	1-3 years \$m	3-5 years \$m	Greater than 5 years \$m	Total \$m	Weighted average term to settlement (years)
<b>31 December 2017</b>						
Marine	75.7	67.2	20.1	15.4	178.4	2.0
Political, accident and contingency	40.5	29.6	6.4	7.8	84.3	2.3
Property	155.2	126.5	37.8	39.8	359.3	2.2
Specialty lines	392.9	516.9	260.9	330.1	1,500.8	3.4
<b>Net insurance liabilities</b>	<b>664.3</b>	<b>740.2</b>	<b>325.2</b>	<b>393.1</b>	<b>2,122.8</b>	

1 Due to the accounting treatment of the new reinsurance contracts with Beazley Underwriting Limited, driven by the 2018 endorsements, the prior year balances disclosed in this section are not directly comparable to current year balances. See note 1 and note 13 for further details.

The next two tables summarise the carrying amount at reporting date of financial instruments analysed by maturity date.

**Maturity**

	<1 yr \$m	1-2 yrs \$m	2-3 yrs \$m	3-4 yrs \$m	4-5 yrs \$m	5-10 yrs \$m	>10 yrs \$m	Total \$m
<b>31 December 2018</b>								
Fixed and floating rate securities	243.2	276.7	453.8	170.1	102.1	50.3	-	1,296.1
Cash and cash equivalents	20.9	-	-	-	-	-	-	20.9
Derivative financial instruments	(6.9)	-	-	-	-	-	-	(6.9)
Borrowings	-	-	-	-	-	(248.7)	-	(248.7)
<b>Total</b>	<b>257.2</b>	<b>276.7</b>	<b>453.8</b>	<b>170.1</b>	<b>102.1</b>	<b>(198.4)</b>	<b>-</b>	<b>1,061.4</b>

	<1 yr \$m	1-2 yrs \$m	2-3 yrs \$m	3-4 yrs \$m	4-5 yrs \$m	5-10 yrs \$m	>10 yrs \$m	Total \$m
<b>31 December 2017</b>								
Fixed and floating rate securities	207.0	338.7	249.1	173.2	105.2	26.3	-	1,099.5
Cash and cash equivalents	23.1	-	-	-	-	-	-	23.1
Derivative financial instruments	4.6	-	-	-	-	-	-	4.6
Borrowings	-	-	-	-	-	(248.5)	-	(248.5)
<b>Total</b>	<b>234.7</b>	<b>338.7</b>	<b>249.1</b>	<b>173.2</b>	<b>105.2</b>	<b>(222.2)</b>	<b>-</b>	<b>878.7</b>

In November 2016, the company issued \$250m of subordinated tier 2 notes due in 2026. Annual interest, at a fixed rate of 5.875%, is payable in May and November each year.

**2.4 Credit risk**

Credit risk arises where counterparties fail to meet their financial obligations in full as they fall due. The primary sources of credit risk for the company are:

- Investments – whereby issuer default results in the company losing all or part of the value of a financial instrument; and
- Amounts receivable under the reinsurance contracts – whereby counterparties fail to pass on premiums due under the reinsurance contracts. The main credit risk exposure facing the company arises by virtue of the reinsurance contract in place with its sister company, Beazley Underwriting Limited and the underlying risk facing that company.

## 2 Risk review *continued*

### 2.4 Credit risk *continued*

The company's core business is to accept significant insurance risk and the appetite for other risks is low. This protects the company's capital from erosion so that it can meet its insurance liabilities. To assist in the understanding of credit risks, A.M. Best, Moody's and Standard & Poor's (S&P) ratings are used. These ratings have been categorised below as used for Lloyd's reporting:

	A.M. Best	Moody's	S&P
Tier 1	A++ to A-	Aaa to A3	AAA to A-
Tier 2	B++ to B-	Baa1 to Ba3	BBB+ to BB-
Tier 3	C++ to C-	B1 to Caa	B+ to CCC
Tier 4	D,E,F,S	Ca to C	R,(U,S) 3

The following tables summarise the company's concentrations of credit risk:

31 December 2018	Tier 1 \$m	Tier 2 \$m	Tier 3 \$m	Tier 4 \$m	Unrated \$m	Total \$m
Financial assets at fair value						
– Fixed and floating rate debt securities	867.8	428.3	–	–	–	1,296.1
– Equity linked funds	–	–	–	–	53.5	53.5
– Hedge funds	–	–	–	–	49.0	49.0
– Derivative financial assets	–	–	–	–	1.0	1.0
Cash and cash equivalents	20.9	–	–	–	–	20.9
Accrued interest	8.7	–	–	–	–	8.7
Claims outstanding, reinsurer's share	–	–	–	–	0.5	0.5
Debtors arising from reinsurance operations	–	–	–	–	121.2	121.2
Debtors arising from direct insurance operations	–	–	–	–	4.3	4.3
<b>Total</b>	<b>897.4</b>	<b>428.3</b>	<b>–</b>	<b>–</b>	<b>229.5</b>	<b>1,555.2</b>

31 December 2017	Tier 1 \$m	Tier 2 \$m	Tier 3 \$m	Tier 4 \$m	Unrated \$m	Total \$m
Financial assets at fair value						
– Fixed and floating rate debt securities	826.1	273.4	–	–	–	1,099.5
– Equity linked funds	–	–	–	–	80.9	80.9
– Hedge funds	–	–	–	–	48.9	48.9
– Derivative financial assets	–	–	–	–	5.0	5.0
Cash and cash equivalents	23.1	–	–	–	–	23.1
Debtors arising from direct insurance operations	–	–	–	–	0.5	0.5
Accrued interest	4.3	–	–	–	–	4.3
Amounts due from group companies	–	–	–	–	2,729.7	2,729.7
<b>Total</b>	<b>853.5</b>	<b>273.4</b>	<b>–</b>	<b>–</b>	<b>2,865.0</b>	<b>3,991.9</b>

The carrying amount of financial assets at the reporting date represents the maximum credit exposure.

At 31 December 2018, the company held no financial assets that were past due or impaired, either for the current year under review or on a cumulative basis.

## 3 Segmental analysis

### a) Reporting segments

Segment information is presented in respect of reportable segments. These are based on the company's management and internal reporting structures and represent the level at which financial information is reported to the board, being the chief operating decision-maker as defined in IFRS 8.



## Notes to the financial statements *continued*

### 3 Segmental analysis *continued*

Driven by the accounting presentation of the new reinsurance contracts following the 2018 endorsements with Beazley Underwriting Limited, the company's segmental analysis is not comparable with the prior year. The revised presentation, splitting the company's activities between insurance and reinsurance activities, reflects the reporting and governance within the company, with the reinsurance underwriting group monitoring the performance of the reinsurance business and the insurance underwriting group monitoring the performance of the insurance business. We further note that from 2018 onwards, the company will only present claims ratios, expense ratios and combined ratios in respect of the direct insurance business. It is the company's view that due to the accounting presentation of the reinsurance contracts with Beazley Underwriting Limited, these ratios are not appropriate performance measures for the company's reinsurance business. The operating segments are presented as described below:

#### Specialty Lines

This segment writes direct insurance business through an EU branch network, focusing solely on specialty lines business including financial institutions and management liability.

#### Reinsurance

This segment writes reinsurance business through an aggregate excess of loss agreement with Beazley Underwriting Limited. The agreement cedes the following business to the company:

- Marine – This segment underwrites a broad spectrum of marine classes including hull, energy, cargo and specie, piracy, satellite, aviation, kidnap & ransom and war risks.
- Political, accident & contingency – This segment underwrites terrorism, political violence, expropriation and credit risks as well as contingency and risks associated with contract frustration. The segment also underwrites health, personal accident, sports and income protection risks.
- Property – The property segment underwrites commercial, high-value homeowners' and construction and engineering property insurance and reinsurance on a worldwide basis.
- Specialty Lines – This segment underwrites professional liability, management liability and environmental liability, including architects and engineers, healthcare, cyber, lawyers, technology, media and business services, directors and officers and employment practices risks.

Segment results, assets and liabilities include items directly attributable to a segment as well as those that can be allocated on a reasonable basis. The reporting segments do not cross-sell business to each other.

#### b) Segment information

31 December 2018	Specialty lines \$m	Reinsurance \$m	Total reportable segments \$m	Unallocated \$m	Total \$m
<b>Segment results</b>					
Gross premiums written	8.2	96.4	104.6	-	104.6
Net earned premiums	2.6	96.4	99.0	-	99.0
Net investment income	-	29.7	29.7	-	29.7
<b>Revenue</b>	<b>2.6</b>	<b>126.1</b>	<b>128.7</b>	<b>-</b>	<b>128.7</b>
Net insurance claims	(1.8)	(32.0)	(33.8)	-	(33.8)
Net operating expenses	(1.7)	(17.0)	(18.7)	-	(18.7)
Foreign exchange loss	-	-	-	(12.3)	(12.3)
Finance costs	-	-	-	(14.9)	(14.9)
<b>Expenses</b>	<b>(3.5)</b>	<b>(49.0)</b>	<b>(52.5)</b>	<b>(27.2)</b>	<b>(79.7)</b>
<b>Profit on ordinary activities before tax</b>	<b>(0.9)</b>	<b>77.1</b>	<b>76.2</b>	<b>(27.2)</b>	<b>49.0</b>
Segment assets	7.0	1,555.6	1,562.6	-	1,562.6
Segment liabilities	(7.9)	(468.1)	(476.0)	-	(476.0)
<b>Net assets</b>	<b>(0.9)</b>	<b>1,087.5</b>	<b>1,086.6</b>	<b>-</b>	<b>1,086.6</b>
	Specialty lines				
<b>Claims ratio</b>	69%				
<b>Expense ratio</b>	65%				
<b>Combined ratio</b>	134%				

### 3 Segmental analysis *continued*

31 December 2017	Marine \$m	PAC \$m	Property \$m	Specialty lines \$m	Total reportable segments \$m	Unallocated \$m	Total \$m
<b>Segment results</b>							
Gross premiums written	174.1	113.3	326.1	798.1	1,411.6	-	1,411.6
Net earned premiums	169.2	119	320.1	725.7	1,334.0	-	1,334.0
Net investment income	13.3	8.1	25.6	79.8	126.8	-	126.8
<b>Revenue</b>	<b>182.5</b>	<b>127.1</b>	<b>345.7</b>	<b>805.5</b>	<b>1,460.8</b>	-	<b>1,460.8</b>
Net insurance claims	(92.2)	(61.9)	(262.1)	(355.0)	(771.2)	-	(771.2)
Net operating expenses	(76.6)	(59.3)	(141.7)	(296.1)	(573.7)	-	(573.7)
Foreign exchange loss	-	-	-	-	-	(5.2)	(5.2)
Finance costs	-	-	-	-	-	(14.9)	(14.9)
<b>Expenses</b>	<b>(168.8)</b>	<b>(121.2)</b>	<b>(403.8)</b>	<b>(651.1)</b>	<b>(1,344.9)</b>	<b>(20.1)</b>	<b>(1,365.0)</b>
<b>Profit on ordinary activities before tax</b>	<b>13.7</b>	<b>5.9</b>	<b>(58.1)</b>	<b>154.4</b>	<b>115.9</b>	<b>(20.1)</b>	<b>95.8</b>
Segment assets	425.1	212.1	803.3	2,793.7	4,234.2	-	4,234.2
Segment liabilities	(312.6)	(156.0)	(590.7)	(2,054.1)	(3,113.4)	-	(3,113.4)
<b>Net assets</b>	<b>112.5</b>	<b>56.1</b>	<b>212.6</b>	<b>739.6</b>	<b>1,120.8</b>	-	<b>1,120.8</b>
<b>Claims ratio</b>	55%	52%	82%	49%	58%		
<b>Expense ratio</b>	45%	50%	44%	41%	43%		
<b>Combined ratio</b>	100%	102%	126%	90%	101%		

An analysis of gross premiums written by reference to the location of the risk insured by the ceding company is provided below<sup>1</sup>. In 2018, over 90% of our premium was sourced from the UK, with the remainder in continental Europe.

	2018 \$m	2017 \$m
Risks located in US	-	903.4
Risks located in Europe	104.6	211.7
Risks located in other countries	-	296.5
	<b>104.6</b>	<b>1,411.6</b>

<sup>1</sup> Due to the accounting treatment of the new reinsurance contracts with Beazley Underwriting Limited, current year balances are not directly comparable to prior year disclosures. See note 1 for further details.

### 4 Investment return

	2018 \$m	2017 \$m
Share of Lloyd's syndicates investment income <sup>1</sup>	-	80.3
Income derived from financial assets	11.0	33.4
Income from intercompany financing arrangements	20.1	19.0
Investment income	<b>31.1</b>	<b>132.7</b>
Investment expenses and charges	(1.4)	(5.9)
	<b>29.7</b>	<b>126.8</b>

<sup>1</sup> Due to the accounting treatment of the new reinsurance contracts with Beazley Underwriting Limited, net investment income on the face of the profit or loss account is not directly comparable year on year. See note 1 for further details.

Notes to the financial statements *continued***5 Net operating expenses**

	2018 \$m	2017 \$m
Share of Lloyd's Syndicates acquisition costs <sup>1</sup>	-	451.4
Share of Lloyd's Syndicates operating expenses <sup>1</sup>	-	99.6
Other administration costs including commissions payable to Beazley Underwriting Limited	18.7	22.7
	<b>18.7</b>	<b>573.7</b>

Administrative expenses include:

	2018 \$	2017 \$
Auditor's remuneration:		
Fees payable for the audit of these annual accounts (€46,150)	52,611	34,756
Fees payable in respect of other services pursuant to legislation (€55,500)	63,270	41,518
Fees payable in respect of tax advisory services	-	-
Fees payable in respect of other non-audit services	-	-
	<b>115,881</b>	<b>76,274</b>

1 Due to the new accounting treatment of reinsurance contracts with Beazley Underwriting Limited, the final declared result of the syndicates is ceded in accordance with the terms of the contract as either a reinsurance premium or a reinsurance claim depending on whether the final declared result is profitable or loss making. As a result, in 2018, the cede of operating expenses included in the final declared result is not reflected in the net operating expenses line of the profit or loss account. In this regard, although the net operating expenses incurred by the syndicates and ceded to the company has not been impacted, net operating expenses on the face of the profit or loss account are not directly comparable year on year.

The average number of persons employed by the company (including executive directors) during the year, analysed by category, was as follows:

Number of employees	2018	2017
Management	1	1
Finance	-	-
Compliance	1	1
Administration	0.5	0.5
	<b>2.5</b>	<b>2.5</b>

**6 Staff numbers and costs**

The aggregate payroll costs of these persons were as follows:

	2018 \$m	2017 \$m
Wages and salaries	0.6	0.4
Social security costs	-	-
<b>Charged to profit or loss account</b>	<b>0.6</b>	<b>0.4</b>

Executive director, M L Bride and Group non-executive director, D A Horton, are both executive directors of the company's parent company, Beazley plc. Non-executive director of the company C M Woods is also a non-executive director of Beazley plc. Details of all director's remuneration is included in the table overleaf.

Of the amount disclosed in the table overleaf, \$0.5m was borne by the company. The remaining amount represents an estimated allocation of the emoluments paid or payable by Beazley plc to certain directors as part of their group wide executive management role. The estimated allocation is based on an estimate of the qualifying services, including management of the affairs of the company, they provided to the company during the year.

## 6 Staff numbers and costs *continued*

	2018 \$m	2017 \$m
Directors' remuneration	0.6	0.5
Pension contributions	-	-
	<b>0.6</b>	<b>0.5</b>

## 7 Taxation

	2018 \$m	2017 \$m
Current tax:		
Irish corporation tax charge	5.3	11.3
Adjustment in respect of prior year	(0.1)	(0.9)
<b>Tax on profit on ordinary activities</b>	<b>5.2</b>	<b>10.4</b>

### *Factors affecting the tax charge for the current period*

The tax charge for the year is lower (2017 lower) than the standard rate of corporation tax in Ireland, 12.5% due to the differences explained below.

	2018 \$m	2017 \$m
Profit on ordinary activities before tax	49.0	95.8
Corporation tax at 12.5%	6.1	12.0
Effect of:		
Permanent differences	(0.8)	(0.7)
Prior year over provision (2017 over provision)	(0.1)	(0.9)
	<b>5.2</b>	<b>10.4</b>

## 8 Financial instruments

### Fair value measurement

The table below summarises financial assets carried at fair value using a valuation hierarchy that reflects the significance of the inputs used in making the measurements. The fair value hierarchy has the following levels:

Level 1 – Valuations based on quoted prices in active markets for identical instruments. An active market is a market in which transactions for the instrument occur with sufficient frequency and volume on an ongoing basis such that quoted prices reflect prices at which an orderly transaction would take place between market participants at the measurement date. Included within level 1 are bonds and treasury bills of government and government agencies which are measured based on quoted prices in active markets.

Level 2 – Valuations based on quoted prices in markets that are not active, or based on pricing models for which significant inputs can be corroborated by observable market data (e.g. interest rates, exchange rates). Included within level 2 are government bonds and treasury bills which are not actively traded, corporate bonds, asset backed securities and mortgage-backed securities.

Level 3 – Valuations based on inputs that are unobservable or for which there is limited market activity against which to measure fair value.

The availability of financial data can vary for different financial assets and is affected by a wide variety of factors, including the type of financial instrument, whether it is new and not yet established in the marketplace, and other characteristics specific to each transaction. To the extent that valuation is based on models or inputs that are unobservable in the market, the determination of fair value requires more judgement. Accordingly the degree of judgement exercised by management in determining fair value is greatest for instruments classified in level 3. The company uses prices and inputs that are current as of the measurement date for valuation of these instruments.

Notes to the financial statements *continued***8 Financial instruments** *continued*

The table below analyses financial instruments measured at fair value at the 31 December 2018, by the level in the fair value hierarchy into which the fair value measurements is categorised:

31 December 2018	Level 1	Level 2	Level 3	Total
Financial assets at fair value through:	\$m	\$m	\$m	\$m
Fixed and floating rate debt securities				
1) Government issued	375.7	-	-	375.7
2) Supernational	-	-	-	-
3) Corporate bonds - Investment grade	-	920.4	-	920.4
Equity linked funds	-	53.5	-	53.5
Hedge funds/uncorrelated strategies	-	49.0	-	49.0
Derivative financial assets	1.0	-	-	1.0
<b>Total financial assets at fair value</b>	<b>376.7</b>	<b>1,022.9</b>	<b>-</b>	<b>1,399.6</b>
Financial liabilities measured at fair value				
Derivative financial liabilities	7.9	-	-	7.9
<b>Total financial liabilities measured at fair value</b>	<b>7.9</b>	<b>-</b>	<b>-</b>	<b>7.9</b>
Financial liabilities not measured at fair value				
Tier 2 subordinated debt (2026) – issued in 2016	-	248.7	-	248.7
<b>Total financial liabilities not measured at fair value</b>	<b>-</b>	<b>248.7</b>	<b>-</b>	<b>248.7</b>

The table below analyses financial instruments measured at fair value at the 31 December 2017, by the level in the fair value hierarchy into which the fair value measurements is categorised:

31 December 2017	Level 1	Level 2	Level 3	Total
Financial assets at fair value through:	\$m	\$m	\$m	\$m
Fixed and floating rate debt securities				
1) Government issued	374.6	-	-	374.6
2) Supernational	11.6	-	-	11.6
3) Corporate bonds - Investment grade	0.5	712.8	-	713.3
Equity linked funds	-	80.9	-	80.9
Hedge funds/uncorrelated strategies	-	48.9	-	48.9
Derivative financial assets	5.0	-	-	5.0
<b>Total financial assets at fair value</b>	<b>391.7</b>	<b>842.6</b>	<b>-</b>	<b>1,234.3</b>
Financial liabilities measured at fair value				
Derivative financial liabilities	0.4	-	-	0.4
<b>Total financial liabilities measured at fair value</b>	<b>0.4</b>	<b>-</b>	<b>-</b>	<b>0.4</b>
Financial liabilities not measured at fair value				
Tier 2 subordinated debt (2026) – issued in 2016	-	248.5	-	248.5
<b>Total financial liabilities not measured at fair value</b>	<b>-</b>	<b>248.5</b>	<b>-</b>	<b>248.5</b>

## 9 Current tax receivable

	2018 \$m	2017 \$m
Current tax receivable	5.3	7.7
	<b>5.3</b>	<b>7.7</b>

## 10 Cash and cash equivalents

	2018 \$m	2017 \$m
Cash at bank and in hand	13.7	19.2
Short term deposits	7.2	3.9
	<b>20.9</b>	<b>23.1</b>

## 11 Deferred acquisition cost

	2018 \$m	2017 \$m
Balance at 1 January	234.2	202.2
Effect of endorsement of reinsurance contracts	(234.1)	-
Additions	1.3	32.0
Balance at 31 December	<b>1.4</b>	<b>234.2</b>

The deferred acquisition costs at 31 December 2018 relate solely to the company's direct insurance business. See note 1 for further details.

## 12 Share capital and other reserves

	2018 \$m	2017 \$m
Authorised: 100,000,000 ordinary shares of (€1) each	128.4	128.4
Allotted, issued and fully paid	-	-

There is one share with a nominal value of €1 in issue. A capital contribution of \$536.3m was received from Beazley plc on 29 June 2009. The company also holds a foreign exchange translation reserve of (\$42.8m). This balance arose on the change in functional currency to USD in 2010.

The company paid a dividend of \$78m (£56.7m), being \$78m per share, dividends in 2018 (2017: \$80.9m, £66m) to its sole shareholder Beazley Ireland Holdings plc.

## 13 Technical provisions

### 13.1 Technical provisions reconciliation

	Provision for unearned premium \$m	Claims outstanding \$m
<b>Gross technical provisions<sup>1</sup></b>		
<b>At 1 January 2018</b>	<b>737.7</b>	<b>2,122.8</b>
Effect of endorsement of reinsurance contracts	(737.2)	(1,991.2)
Exchange adjustments	(0.2)	(0.1)
Movement in provision	5.1	34.2
<b>At 31 December 2018</b>	<b>5.4</b>	<b>165.7</b>

Notes to the financial statements *continued*13 Technical provisions *continued*

	Provision for unearned premium \$m	Claims outstanding \$m
<b>Reinsurer's share of technical provisions</b>		
<b>At 1 January 2018</b>	(0.2)	-
Exchange adjustments	0.1	(0.1)
Movement in provision	(0.6)	(0.4)
<b>At 31 December 2018</b>	<b>(0.7)</b>	<b>(0.5)</b>
<b>Net technical provisions</b>		
At 31 December 2018	4.7	165.2
<b>At 1 January 2018</b>	<b>737.5</b>	<b>2,122.8</b>

1 Due to the accounting treatment of new reinsurance contracts with Beazley Underwriting Limited, driven by the 2018 endorsements, the presentation of gross technical provisions relevant to these contracts is different to the prior year. These contracts have no provision for unearned premium balance as premium recognised in the profit or loss account is fully earned. The closing provision for unearned premium balance therefore represents direct insurance business only. The closing claims outstanding balance represents claims reserves recognised from the reinsurance contracts with Beazley Underwriting Limited as well as claims reserves from direct insurance business. In the prior year this balance represented the company's share of the syndicates' claims reserves. The current year closing balance of technical provisions is not directly comparable to prior year balances. Further information on the impact of the endorsements on technical balances at 1 Jan 2018 is provided in note 1 and note 15 of the financial statements.

	Provision for unearned premium \$m	Claims outstanding \$m
<b>Gross technical provisions</b>		
<b>At 1 January 2017</b>	654.3	1,946.6
Exchange adjustments	5.8	23.7
Movement in provision	77.6	152.5
<b>At 31 December 2017</b>	<b>737.7</b>	<b>2,122.8</b>
<b>Reinsurers' share of technical provisions</b>		
<b>At 1 January 2017</b>	-	-
Exchange adjustments	-	-
Movement in provision	(0.2)	-
<b>At 31 December 2017</b>	<b>(0.2)</b>	-
<b>Net technical provisions</b>		
At 31 December 2017	737.5	2,122.8
<b>At 1 January 2017</b>	<b>654.3</b>	<b>1,946.6</b>

## 13.2 Technical provisions breakdown

As noted above, outstanding claims include claims reserves in respect of the company's insurance activities, as well as claims reserves held in respect of the company's reinsurance contracts with Beazley Underwriting Limited. The current year claims reserves are split as follows:

	Gross \$m	Net \$m
2018 underwriting year reinsurance contract	88.0	88.0
2017 underwriting year reinsurance contract	75.5	75.5
Direct insurance	7.6	6.4
<b>At 31 December 2018</b>	<b>171.1</b>	<b>169.9</b>

## 13 Technical provisions *continued*

### 13.3 Loss development tables

The following claims development tables have been restructured in this year's financial statements to reflect the accounting treatment of the new reinsurance contracts with Beazley Underwriting Limited. The tables presented reflect the gross and net claims development of direct insurance business written through the company's EU branch network (on a percentage of gross premium basis) and separately the absolute claims development of open year reinsurance contracts in place with Beazley Underwriting Limited. The final table reconciles the claims development of all insurance and reinsurance activities to the balance sheet of the company. Each table is split by underwriting year.

	2017 %	2018 %		
<b>Gross claims development direct insurance</b>				
12 months	59.9	73.5		
24 months	59.9			
	2017 \$m	2018 \$m	Total \$m	
<b>Gross claims liabilities, Direct insurance</b>	<b>0.4</b>	<b>1.8</b>	<b>2.2</b>	
<b>Net claims development direct insurance</b>				
12 months	53.4	69.9		
24 months	53.4			
	2017 \$m	2018 \$m	Total \$m	
<b>Net claims liabilities, Direct Insurance</b>	<b>0.2</b>	<b>1.5</b>	<b>1.7</b>	
<b>Gross/Net claims development reinsurance</b>				
12 months	41.3	131.5	88.0	
24 months	-	75.5		
36 months	-			
	2016 \$m	2017 \$m	2018 \$m	Total \$m
<b>Gross and net claims liabilities, Reinsurance</b>	<b>-</b>	<b>75.5</b>	<b>88.0</b>	<b>163.5</b>
	2016 \$m	2017 \$m	2018 \$m	Total \$m
<b>Gross claims liabilities, Total</b>	<b>-</b>	<b>75.9</b>	<b>89.8</b>	<b>165.7</b>
	2016 \$m	2017 \$m	2018 \$m	Total \$m
<b>Net claims liabilities, Total</b>	<b>-</b>	<b>75.7</b>	<b>89.5</b>	<b>165.2</b>



Notes to the financial statements *continued***14 Debtors arising from reinsurance activities**

The following table displays the amounts due from Beazley Underwriting Limited under the excess of loss reinsurance agreements. Debtors arising from reinsurance activities are recognised when a reinsurance contract is in a profitable position at the reporting date. As these reinsurance contracts were not in place in their current form in the prior year, no prior year balance is displayed.

	2018 \$m	2017 \$m
Balance at 1 January 2018	-	-
Effect of endorsement of reinsurance contracts	24.8	-
Additions	96.4	-
<b>Balance at 31 December 2018</b>	<b>121.2</b>	-

The following table provides an additional split of reinsurance debtors, into each open year of account contract in place at the reporting date:

	2016 \$m	2017 \$m	2018 \$m
Balance at 1 January 2018	-	-	-
Effect of endorsement of reinsurance contracts	24.8	-	-
Additions	96.4	-	-
<b>Balance at 31 December 2018</b>	<b>121.2</b>	-	-

Further information on the impact of the endorsements on technical balances at 1 January 2018 is provided in note 1, note 13 and note 15 of the financial statements.

**15 Reinsurance contract endorsements**

The following table provides additional information as to how the endorsements of the open year reinsurance contracts with Beazley Underwriting Limited were reflected on the company's balance sheet as at 1 January 2018.

Balance Sheet	Pre endorsement 1 January 2018 \$m	2016 year of account endorsement \$m	2017 year of account endorsement \$m	Post endorsement 1 January 2018 \$m
<b>Assets</b>				
Fixed Assets	0.2	-	-	0.2
Investments	1,234.3	-	-	1,234.3
Reinsurer's share of technical provisions	0.2	-	-	0.2
Debtors arising from reinsurance operations	-	24.8	-	24.8
Debtors	2,737.9	(1,771.2)	(747.9)	218.8
Cash	23.1	-	-	23.1
Prepayments and accrued income	238.5	(22.6)	(211.5)	4.4
<b>Total assets</b>	<b>4,234.2</b>	<b>(1,769.0)</b>	<b>(959.4)</b>	<b>1,505.8</b>
<b>Liabilities</b>				
Technical provisions	2,860.5	(1,769.0)	(959.4)	132.1
Creditors	4.0	-	-	4.0
Financial liabilities	248.9	-	-	248.9
<b>Total Liabilities</b>	<b>3,113.4</b>	<b>(1,769.0)</b>	<b>(959.4)</b>	<b>385.0</b>
<b>Net Assets</b>	<b>1,120.8</b>	<b>-</b>	<b>-</b>	<b>1,120.8</b>

## 16 Funds at Lloyd's

The Funds at Lloyd's to support the underwriting of Beazley Underwriting Limited on syndicates 2623 and 3623 have been provided by the company by way of deposits of \$994.3m (2017: \$856.1m).

The Funds at Lloyd's, included in financial assets on the company's balance sheet, may consist of certain approved assets only and are subject to a deed of charge in favour of Lloyd's. In return for providing the Funds at Lloyd's, Beazley Underwriting Limited pays the company an annual fee.

## 17 Related parties

The direct owner of the company's share capital is Beazley Ireland Holdings plc and ultimate controlling party is Beazley plc.

## 18 Ultimate parent undertaking

The ultimate parent undertaking is Beazley plc, incorporated and resident in the United Kingdom.

The largest group in which the results of the company are consolidated is that headed by Beazley plc. The accounts of Beazley plc are available to the public at [www.beazley.com](http://www.beazley.com) and at Plantation Place South, 60 Great Tower Street, London EC3R 5AD, United Kingdom.

The smallest group in which the results of the company are consolidated is that headed by Beazley Ireland Holdings plc. The accounts of Beazley Ireland Holdings plc are available to the public at [www.beazley.com](http://www.beazley.com) and at 2 Northwood Avenue, Santry, Dublin (D09 X5N9).

No other group financial statements include the results of the company.

## 19 Financial liabilities

	2018 \$m	2017 \$m
<b>Carrying value</b>		
Tier 2 subordinated debt (2016) – issued in 2016	248.7	248.5
Derivative financial instruments	7.9	0.4
<b>Total financial liabilities</b>	<b>256.6</b>	<b>248.9</b>
<b>Fair value</b>		
Tier 2 subordinated debt (2016) – issued in 2016	249.4	266.6
Derivative financial instruments	7.9	0.4
<b>Total financial liabilities</b>	<b>257.3</b>	<b>267.0</b>

The fair value of the tier 2 subordinated debt is based on quoted market price.

In November 2016, the company issued \$250m of subordinated tier 2 notes due in 2026. This debt is listed on the London Stock Exchange. Annual interest, at a fixed rate of 5.875%, is payable in May and November each year.

Interest paid on this debt during 2018 was \$14.9m (2017: \$14.9m).

## 20 Post balance sheet events

No events occurred in the period post year end to the date of signing the financial statements that would impact the results, operations or note disclosures of the financial statements of the company.

## 21 Approval of financial statements

The board of directors approved these financial statements on 15 April 2019.

# Directors and advisors

---

## Directors

M L Bride (French)  
P O Desaulle (French)  
D A Horton (British)  
E J McGivney  
K Murphy (appointed 27 July 2018)  
I C Stuart  
C M Woods (chairperson)

## Secretary

R Yeoman

## Registered office

2 Northwood Avenue  
Santry  
Dublin  
D09 X5N9

## Registered number

464758

## Auditor

KPMG  
1 Harbourmaster Place  
IFSC  
Dublin  
D01 F6F5

## Banker

Bank of Ireland  
2 College Green  
Dublin 2  
D02 VR66

## Solicitors

William Fry  
2 Grand Canal Square  
Dublin  
D02 A342

If you have finished reading this report and no longer wish to keep it, please pass it on to other interested readers, return it to Beazley or recycle it. Thank you.

*Designed and produced by:  
Instinctif Partners [creative.instinctif.com](http://creative.instinctif.com)*



Beazley online annual report  
and accounts 2018

[investor.relations.beazley.com](http://investor.relations.beazley.com)

Beazley Insurance dac

2 Northwood Avenue  
Santry  
Dublin  
D09 X5N9  
Ireland

Phone: +353 (0)1 854 4700  
Email: [info@beazley.ie](mailto:info@beazley.ie)

[www.beazley.com](http://www.beazley.com)

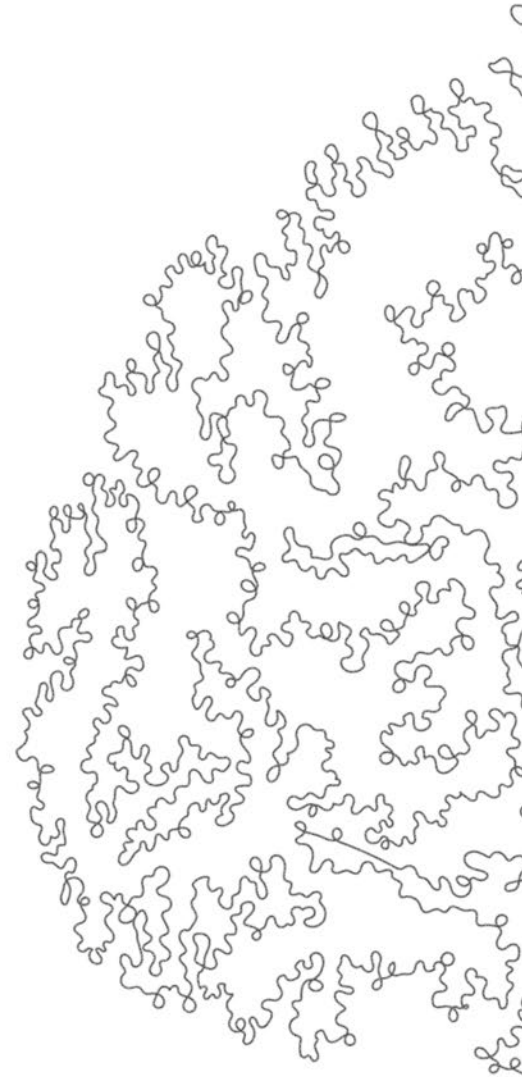

beazley

beautifully  
designed  
insurance